

S316D RVS 3-weg kogelkraan PN16 - DN 15 t/m DN 100



Omschrijving

- 3-weg kogelkraan met flens aansluiting PN16
- Volle doorlaat, L- of T-poort
- Huis, kogel en spindel RVS316
- Opbouwflens ISO 5211 voor directe opbouw pneumatische of elektrische aandrijving
- Zittingen en afdichtingen PTFE
- Drukklasse PN16, flens RF DIN2501
- Verzekerde spindel, vergrendelbare hendel
- Anti statisch
- Temperatuur -30° C tot 200° C
- DN 65, 80 en 100 Trunnion Mount

Opties:

- Automatische elektrische of pneumatische bediening
- Spindelverlenging TFM zittingen
- Eindschakelaars Peek zittingen
- Veerretour hendel tot DN 50 Integraal zittingen
- 4-weg uitvoering L-T-X of I poort

Certificaten:

- 3.1 Materiaal certificaat
- CE verklaring

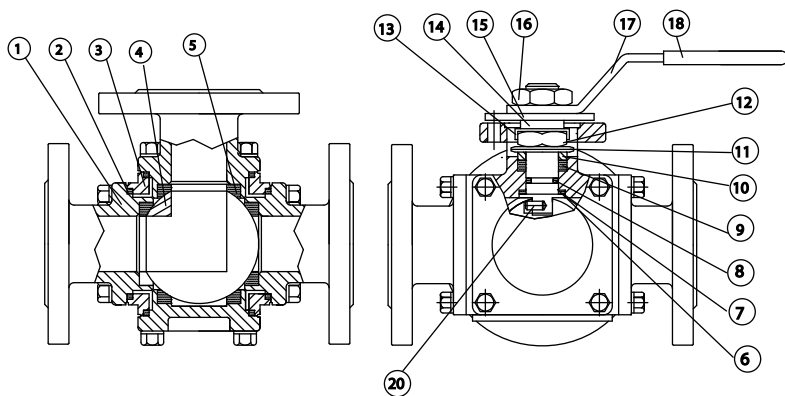

DN15 - 50

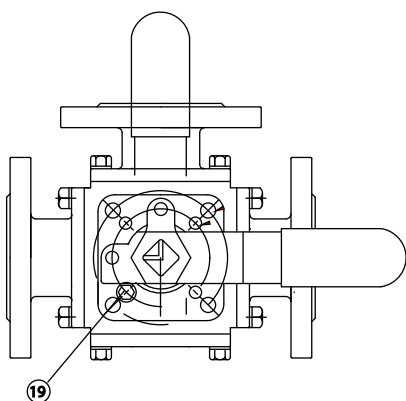

Item	Omschrijving	Materiaal
1	Flens einde	RVS 316
2	Pakking	PTFE
3	Huis	RVS 316
4	Kogel	RVS 316
5	Zitting	PTFE
6	Frictieplaatje	RPTFE
7	Spindel	RVS 316
8	O-ring	Viton®
9	Spindelafdichting	PTFE
10	Pakkingdrukker	RVS
11	Schotelveer	RVS
12	Moer	RVS
13	Zekering	RVS
14	Tussen ring	RVS
15	Stopplaat	RVS
16	Moer	RVS
17	Hendel	RVS
18	Handgreep	PVC
19	Stop pen	RVS
20	Kogeltje + veer	RVS 316

S316D RVS 3-weg kogelkraan PN16 - DN 15 t/m DN 100

DN 65-80-100

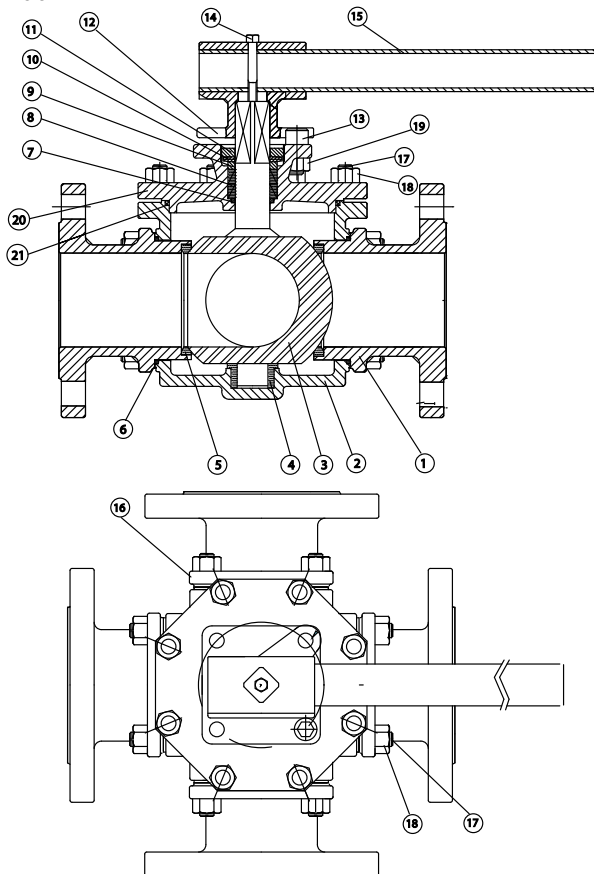

Item	Omschrijving	Materiaal
1	Flens einde	RVS 316
2	Huis	RVS 316
3	Kogel en spindel	RVS 316
4	Lagering	PTFE+RVS
5	Zitting	PTFE
6	Afdichting	PTFE
7	O-ring	Viton®
8	Spindelafdichting	PTFE
9	Pakkingdrukker	RVS
10	Schotelveer	RVS
11	Stopplaat	RVS
12	Hendelkop	RVS
13	Stop pen	RVS
14	Bout	RVS
15	Hendel	Staal
16	Deksel (bij 3-weg)	RVS 316
17	Bout	RVS
18	Moer	RVS
19	Stop pen moer	RVS
20	Deksel	RVS 316
21	Dichting	PTFE

Positie mogelijkheden kogel L- en T poort

L - PORT 90° TURN

T - PORT 90° TURN

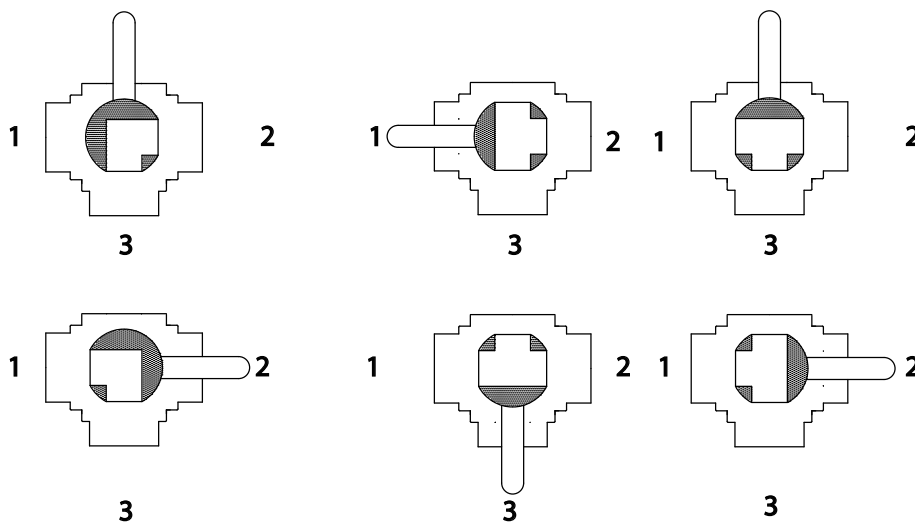

S316D RVS 3-weg kogelkraan PN16 - DN 15 t/m DN 100

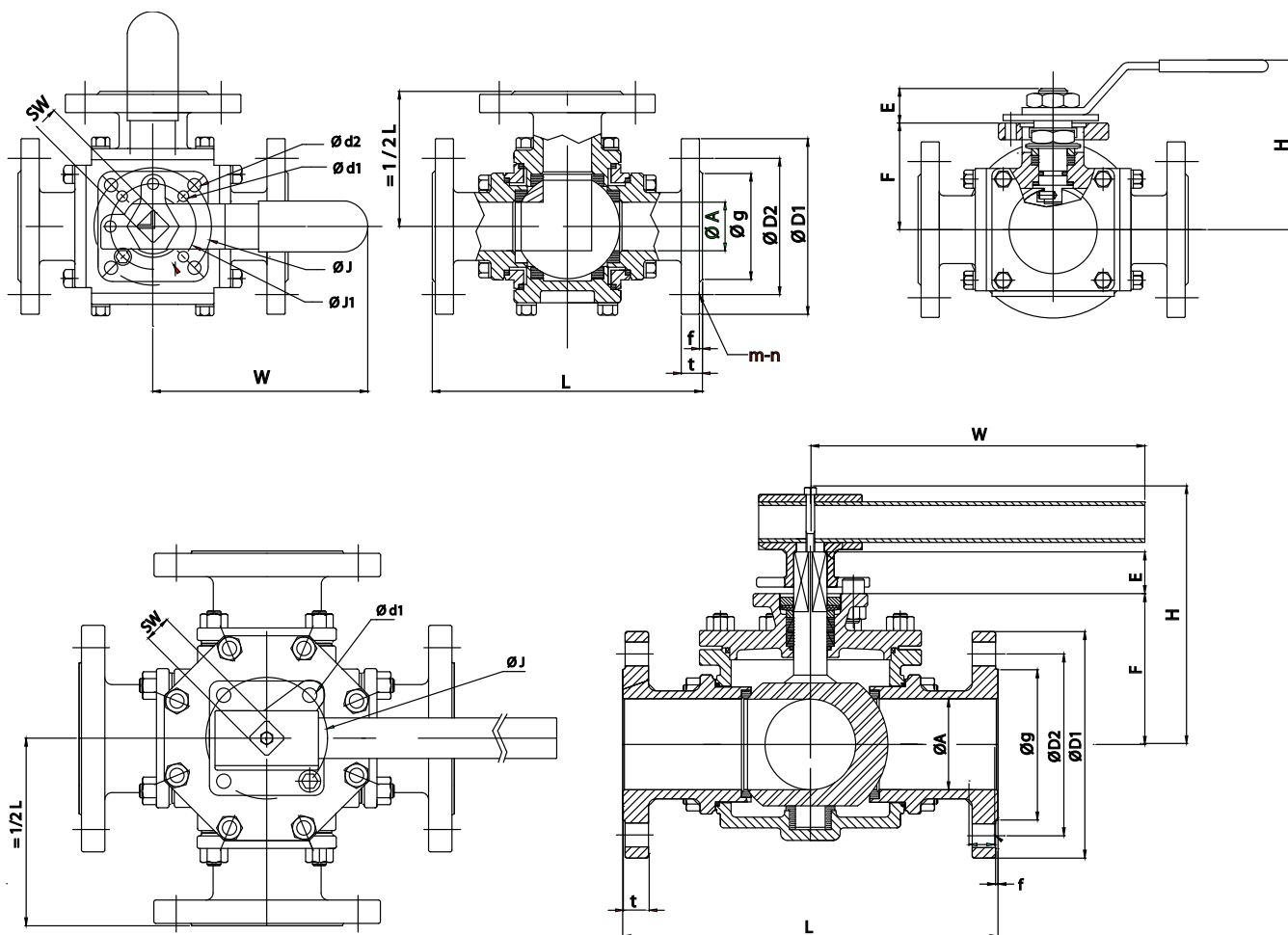

Afmetingen 1/4" t/m 2" [mm] volle doorlaat									
DN	15	20	25	32	40	50	65	80	100
A	15	20	25	32	38	50	62	76	96
L	160	177	190	208	234	273	300	305	368.5
H	62	82	89	98	108	140	200	218	230
W	130	165	165	205	205	325	400	500	650
F	41	49	55	63	74	93	118.5	136.5	156.5
E	11	14	14	18	18	23	25	25	25
J	42	50	50	70	70	102	102	102	102
J1	36	42	42	50	50	70	-	-	-
d1	6.0	6.0	6.0	7.1	7.1	9.2	11	11	11
d2	6.0	7.1	7.1	9.2	9.2	11.4	-	-	-
SW	9	11	11	14	14	17	22	22	22
g	45	58	68	78	88	102	122	138	158
D1	95	105	115	140	150	165	185	200	220
D2	65	75	85	100	110	125	145	160	180
f-t	2-14	2-16	2-16	2-16	3-16	3-18	3-18	3-20	3-20
Gewicht [kg]	4.36	5.62	7.2	10.54	14.52	23.52	28.1	36.58	60.3

S316D RVS 3-weg kogelkraan PN16 - DN 15 t/m DN 100

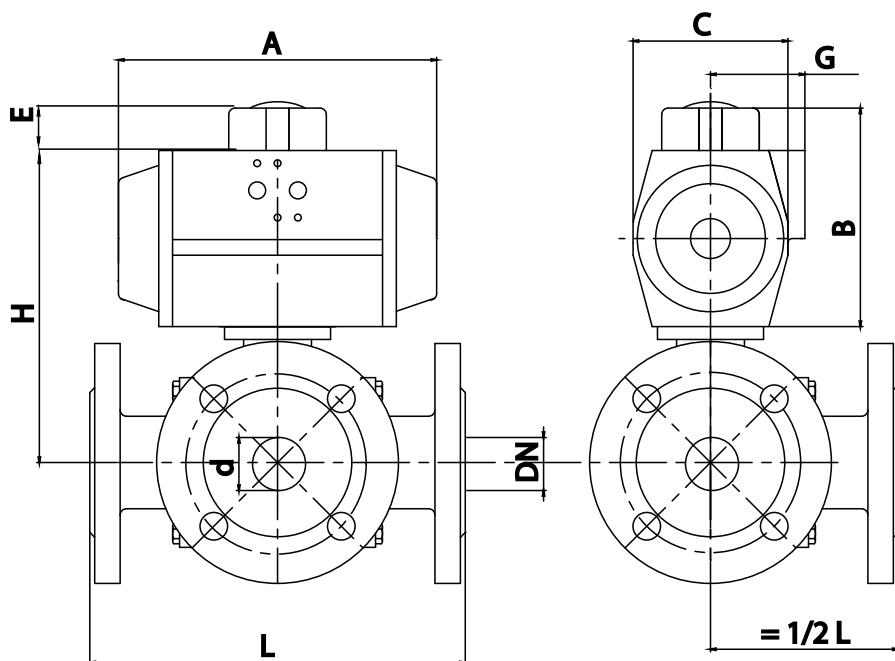

Met dubbelwerkende pneumatische actuator [mm]										
DN (d)	DW	A	B	C	E	d	G	H	L	Gewicht [kg]
DN15 (1/2")	AP1D	142	67	60	20	15	41	88	160	5.2
DN20 (3/4")	AP2D	155	83	73	20	20	44.5	112	177	6.8
DN25 (1")	AP3D	213	100	85	20	25	49.5	135	190	9.7
DN32 (1 1/4")	AP3D	213	100	85	20	32	49.5	143	208	13.1
DN40 (1 1/2")	AP3D	213	100	85	20	38	49.5	154	234	16.9
DN50 (2")	AP3.5D	236	110	98	20	50	53	183	273	27.4
DN65 (2 1/2")	AP4.5D	310	142	128	30	62	69	230.5	300	35.7
DN80 (3")	AP4.5D	310	142	128	30	76	69	248.5	305	47.1
DN100 (4")	AP5D	366	155	140	30	96	-	281.5	368.5	69.5

Met enkelwerkende pneumatische actuator [mm]										
DN (d)	EW	A	B	C	E	d	G	H	L	Gewicht [kg]
DN15 (1/2")	AP2S	155	83	73	20	15	44.5	104	160	5.8
DN20 (3/4")	AP3S	213	100	85	20	20	49.5	129	177	8.5
DN25 (1")	AP3S	213	100	85	20	25	49.5	135	190	10.1
DN32 (1 1/4")	AP3.5S	236	110	98	20	32	53	153	208	14.9
DN40 (1 1/2")	AP4S	273	125	110	30	38	58	169	234	20.3
DN50 (2")	AP4.5S	310	142	128	30	50	69	205	273	33.1
DN65 (2 1/2")	AP5.5S	388	176	160	30	62	-	324.5 (D)	300	45.6
DN80 (3")	AP5.5S	388	176	160	30	76	-	342.5 (D)	305	57.2
DN100 (4")	AP6S	468	200	175	30	96	-	386.5 (D)	368.5	83.5

Pneumatische aandrijvingen zijn berekend o.b.v. PTFE zittingen, een minimale stuurdruk van 6 bar(g) en schoon medium water 20°C met een druk van 6 bar.

* (D)= opbouw met brugstuk